

IT560CL

1. Retirar la tapa que cubre la transmisión donde se sitúa el embrague.

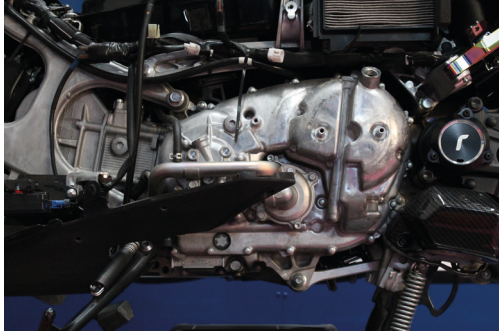

2. Retirar el embrague de origen.

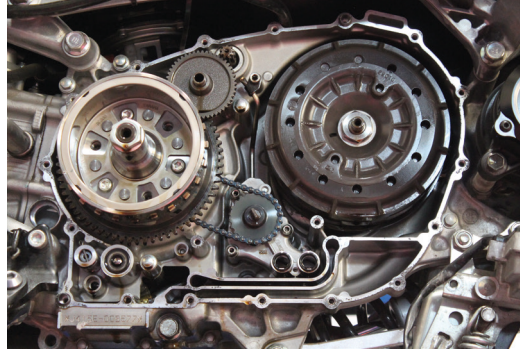

3. Presentar encima de la mesa el embrague de origen junto con el J.Costa.



4. Retirar el conjunto de discos del embrague original y reservar.

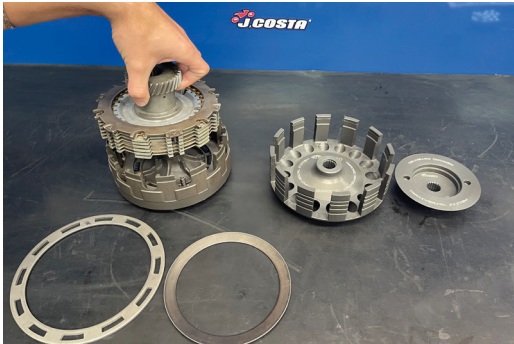

5. Retirar el último disco y colocar en el embrague J.Costa.

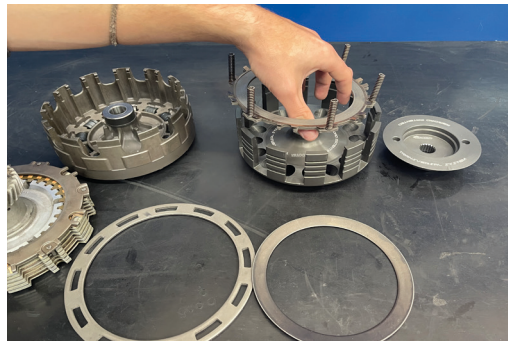

6. Quitar rodamiento central del embrague de origen y colocar en el embrague J.Costa.

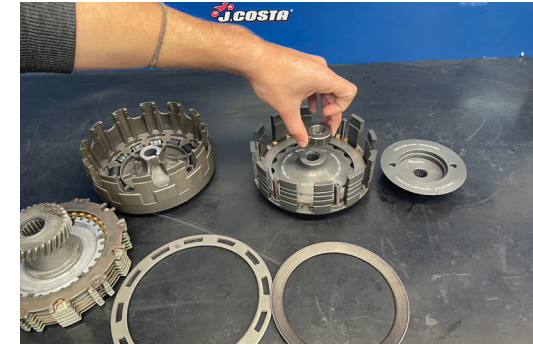

7. Introducir el conjunto de discos en el embrague J.Costa y dejar el resorte de embrague.



8. Terminar de montar los discos restantes con el mismo orden que de origen.



9. Una vez terminados los pasos anteriores, debe quedar el embrague J.Costa como en la foto:



IT560CL

10. Colocar los contrapesos.



11. Montar el conjunto en la scooter.



12. Apretar con dinamometrica (9Kg/90Nm).

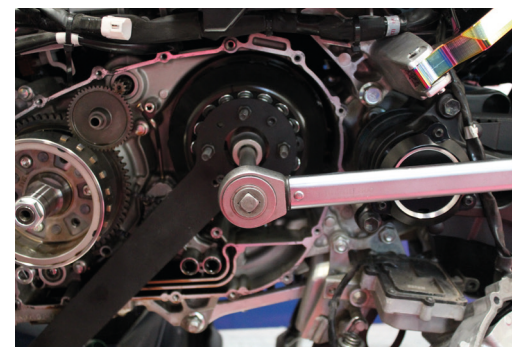

13. Volver a montar la tapa de transmisión que cubre el embrague.

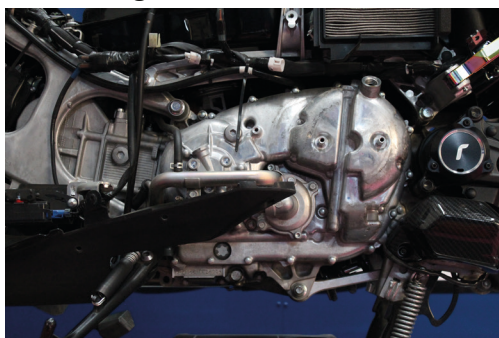

COMPONENTES

Contrapesos: Ø5 x 16 (IT22165R)

Cuerpo: 530.E

Araña: IT530EA

DESPIECE EMBRAGUE ORIGINAL

T-MAX 560cc

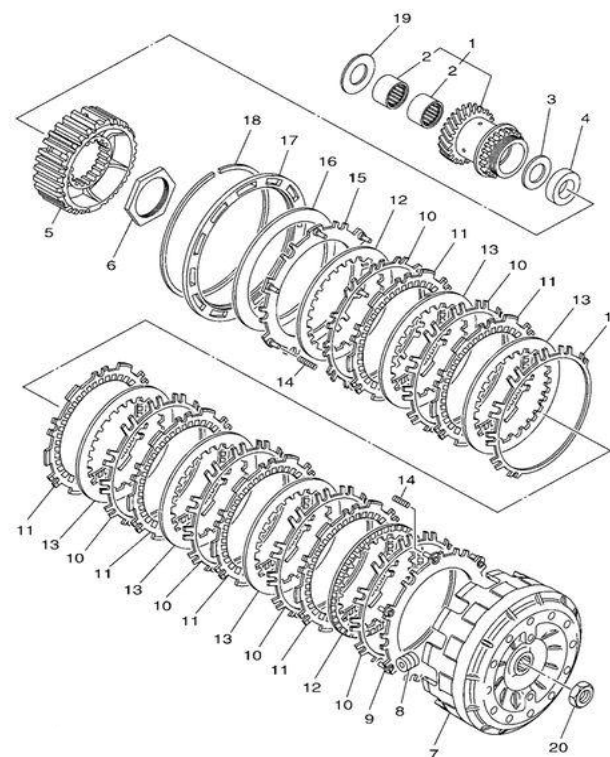

MOUNTING INSTRUCTIONS J.COSTA CLUTCH

IT560CL

1. Remove the cover that covers the transmission where the clutch is located. 2. Remove the original clutch.

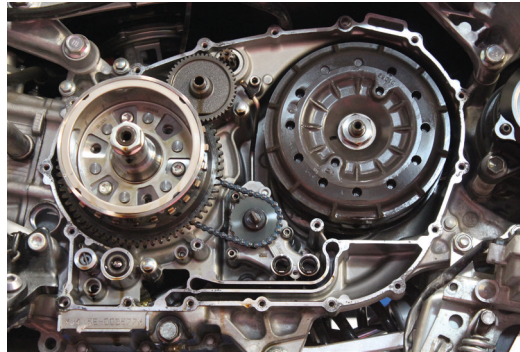
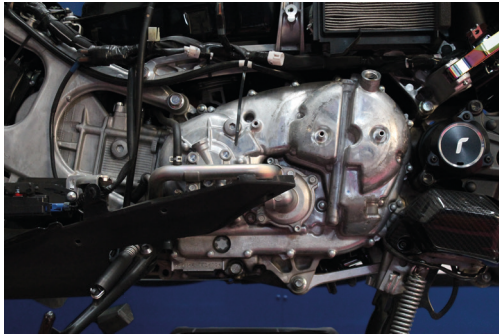

3. In the table presented the original clutch and also J.Costa clutch.



4. Remove the disk clutch from the original one and reserve. 5. Remove the last disk and put in the J.Costa clutch. 6. Remove center bearing from the original clutch and place on the J.Costa clutch.

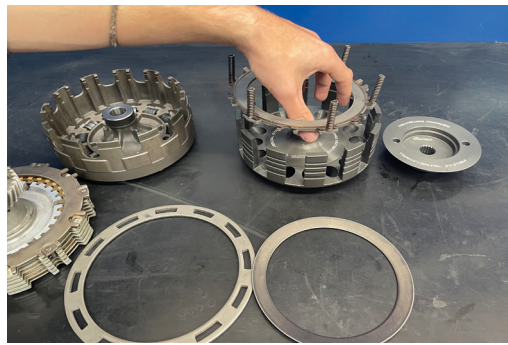
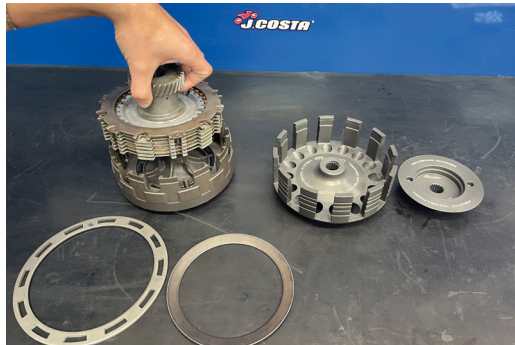

7. Insert the disc assembly into the J.Costa clutch and put the clutch spring. 8. Finish mounting the remaining disks in the same order as the original. 9. Once the previous steps are finished, the J.Costa clutch should remain as in the photo:



MOUNTING INSTRUCTIONS J.COSTA CLUTCH

IT560CL

10. Place the counterweights.



11. Mount the set on the scooter.



12. Tighten with dynamometer (9Kg / 90Nm).

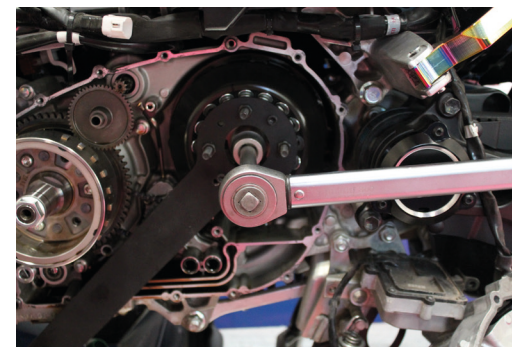

13. Reassemble the transmission cover that covers the clutch.

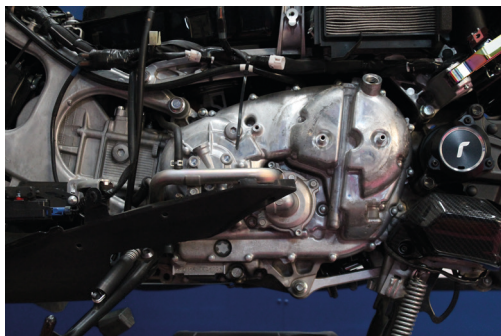

ORIGINAL CLUTCH DRAWING FOR T-MAX 560cc

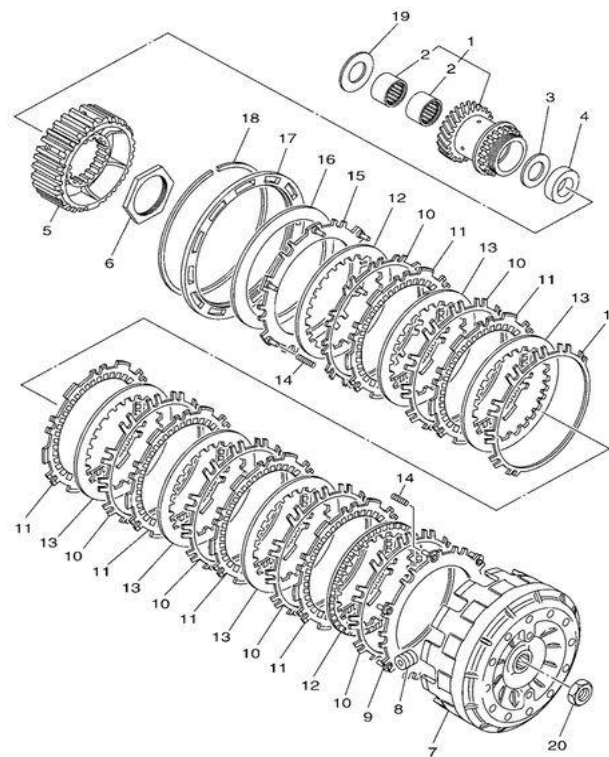

COMPONENTS

Counterweights: $\varnothing 5 \times 16$ (IT22165R)

Body: 530.E

Spider: IT530EA

IT560CL

1. Retirer le couvercle qui couvre le système de transmission où est l'embrayage. 2. Retirer l'embrayage d'origine.

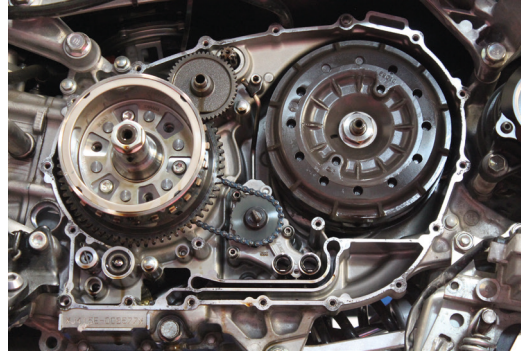
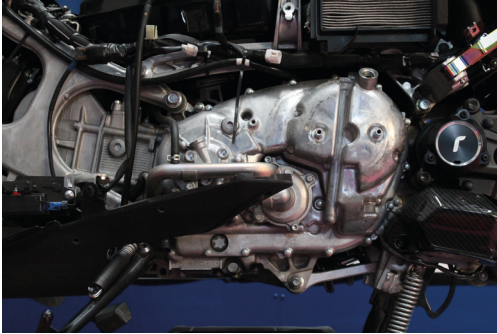

3. Présenter sur la table l'embrayage d'origine à côté du J. Costa.



4. Retirer le jeu de disques d'embrayage originaux et réserver.

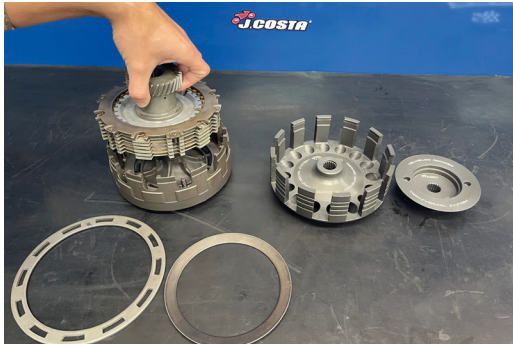

5. Retirer de dernier disque et placer dans l'embrayage J. Costa.

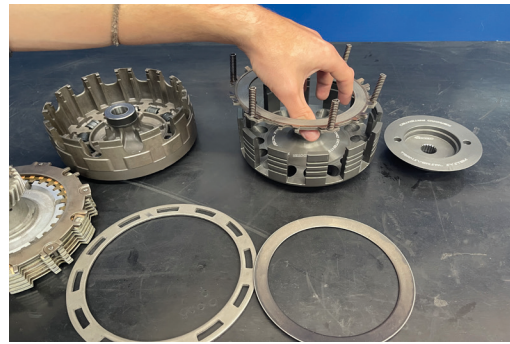

6. Enlever le roulement central de l'embrayage d'origine et placer sur l'embrayage J. Costa.



7. Mettre le jeu de disques dans l'embrayage J.Costa et poser le ressort d'embrayage.



8. Finir d'installer le reste de disques avec la même position que ce d'origine.



9. Une fois les étapes précédentes terminées, on doit avoir l'embrayage J. Costa comment ça de la photo :



IT560CL

10. Installer les contrepoids.



11. Installer l'ensemble sur l'scooter.



12. Serrer avec la clé dynamométrique (9kg/90Nm).

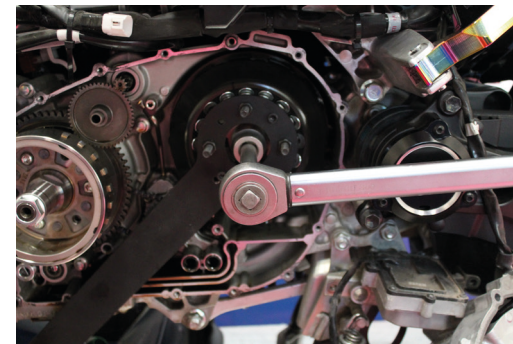

13. Replacer le couvercle de transmission qui couvre l'embrayage.

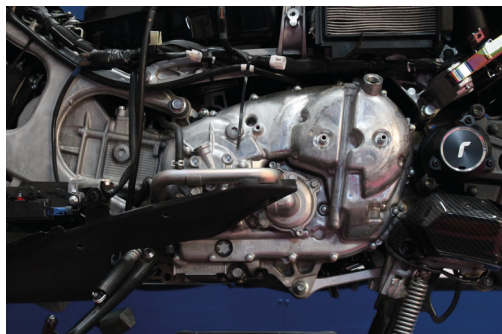

VUE ÉCLATÉE EMBRAYAGE ORIGINAL T-MAX 560cc

COMPOSANTS

Contrepoids: $\varnothing 5 \times 16$ (IT22165R)

Corps: 530.E

Araignée: IT530EA

